

ROSS Dual Shaft Mixers (CDA 1Qt - 4) Specifications and Dimensions

STANDARD FEATURES:

- Change can design
- Air/oil hydraulic lift with two-hand operation air-powered controls for raising and lowering the mix can to and from the mixing position
- Integrated base design for mounting on table top or work bench
- Agitator drive components and lift system are fully sheathed
- Stainless steel type 304 wetted parts with 80 grit polish
- Non-stainless steel components are finished with a durable two-part epoxy coating
- Two independently-driven agitators:
Two Wing Anchor and High Speed Disperser
- TEFC motors designed for 230/460 volt, 3 phase, 50/60 Hz
- Safety limit switch to prevent operation of the agitators when the mix vessel is removed or not in the mixing position

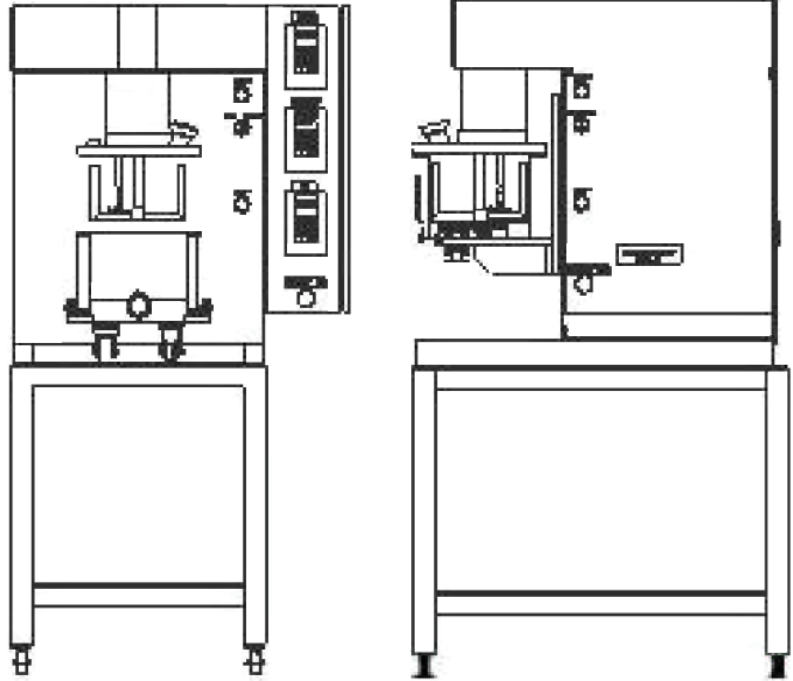

AVAILABLE OPTIONS:

- Wetted parts can be stainless steel type 316, Hastelloy or other special alloys
- Vacuum and/or internal pressure capability
- Sanitary design with special seals, polishes, connections and stainless steel sheathing
- High Shear Rotor/Stator Mixer in lieu of High Speed Disperser
- Sight/charge ports, inlet/outlet nozzles and tank light
- Flush tank discharge valves
- Temperature probes, pressure transducers and other sensors
- Jacketed mix vessel for heating and/or cooling (ASME Stamp can be provided, if required)
- Internally-machined mix vessel for use with a Ross Discharge System
- Carbon steel or stainless steel mixer bench. Common bench design also offered for mounting both mixer and Discharge System.
- Controls including variable frequency drives, touchscreen control panel and PLC recipe controls
- Vacuum pump, heater, chiller and other auxiliary equipment
- Custom agitators and other special features

Model	Mixing Capacity	Anchor		High Speed Disperser		Overall Height	Overall Width	Overall Length	Mix Vessel Inside Height	Mix Vessel Inside Diameter	Weight
	Gallons	HP	RPM	HP	RPM	inches	inches	inches	inches	inches	lbs
CDA-1Qt	0.125 - 0.25	1/2	35 - 320	1/2	600 - 6,000	68	18	30	5	5.8	800
CDA-1/2	0.25 - 0.5	1/2	23 - 230	1	950 - 9,500	68	25	36	5.5	5.5	800
CDA-1	0.3 - 0.75	1/2	19 - 190	1	1,000 - 10,000	68	33	36	6.5	8.25	1,000
CDA-2	1 - 1.5	1/2	19 - 190	1	1,000 - 10,000	68	33	36	7.6	9.6	1,000
CDA-4	3 - 4	1	13 - 135	2	600 - 6,000	68	33	36	9.6	14	1,200

*Dimensions shown are approximate and subject to change without notice due to design improvements, selected options, or supplier component substitutions.



CHARLES ROSS & SON COMPANY
P.O. Box 12308
710 Old Willets Path, Hauppauge, NY 11788
631-234-0500 Fax: 631-234-0691
www.mixers.com
sales@mixers.com